

# SHIPPING ADVICE - ISPM 15 Markings

V-EMB POOL Packaging

*English*

The diagram illustrates the correct application of ISPM-15 markings. It is divided into several sections:

- Top Left:** A stack of shipping documents with a signature and a vertical IPPC logo.
- Top Right:** A 3D perspective of a wooden crate with a large 'ISPM-15' marking on its side.
- Center:** A rectangular label with the IPPC logo on the left and the text 'GB-FC0000 HT' on the right.
- Bottom Left:** A perspective view of a wooden pallet with a 'V-EMB' marking on its side and a 'V-EMB ENB 752 05-05 2011' marking on its top surface.
- Bottom Right:** A vertical column of five rectangular labels. The first two are marked with a checkmark (✓) and contain the text 'SE-AB123 HT' and 'GB-FC0000 HT' respectively. The remaining three are marked with an 'X' and contain the text 'SE-AB123 HT', 'SE-AB123 HT', and 'GB-FC0000 HT' respectively, representing incorrect or illegible markings.

# EXPORT

**VERSION**  
**1.1**

## Information Sheet :

## International Shipment of VOLVO ( V-EMB ) Wooden Packaging

Considerable damage and loss to native tree populations has been caused by uncontrolled pests and organisms spreading from country to country. Non treated Wooden packaging material is believed to have played a part in this, as a consequence;

The International Standard for Phytosanitary Measures No. 15 (ISPM 15) was created and adopted in March 2002 by the IPPC, (International Plant Protection Convention) , and is now under implementation globally.

These regulations set a common standard for Wooden material used in International trade.

The ISPM 15 Rules dictate that All Non manufactured Wood should be De-barked and Heat-treated and marked preferably on at least two opposite sides. ( fig 1 ) to an agreed standard.

The markings should contain:

- The IPPC Symbol,
- (XX) ISO 2 Letter country code
- (0000) Unique Producer / Treatment provider registration number
- (YY) Internationally agreed abbreviation Treatment code.

Fig 1- ISPM Official Marking

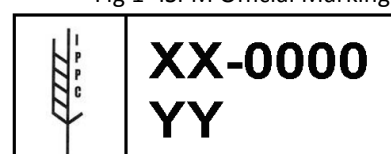

Most Volvo packaging has for many years, (prior to these standards ) been debarked and heat treated, however in order to comply – Packaging MUST now have the new approved markings. (fig 1)

Failure to comply with these regulations may cause shipments to be denied entry to a country, resulting in costly delays and potential disturbances to Production.

When you order packaging from Volvo, our aim is to provide you with 100% compliant material. However there is a risk you may receive some that is not . It is your responsibility to check each piece prior to use. Non compliant packaging can be used inside the EU or the country you are in, but should not be used for international flows. If you have packaging that cannot be used in any flows please contact our Support Team . Tel: +46(0) 31 66 15 08 email :POD.EMEA@volvo.com

Repaired Packaging may have additional ISPM marks – Please remember compliant packaging needs visible stamps when in use.

Fig 2- ISPM Marking locations for Volvo Packaging

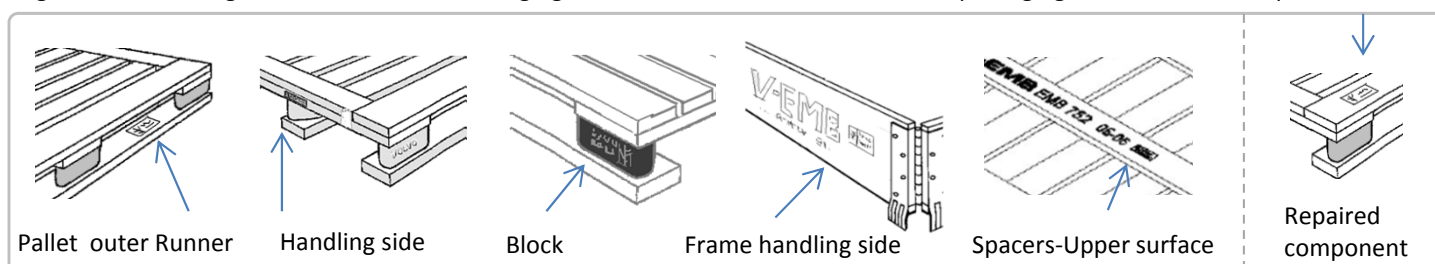

Whilst regulations state that packaging with a single visible mark is compliant, the use of the words 'preferably two ' in the official ISPM 15 text can be sometimes be translated by Customs as a requirement, we would therefore advise that export packaging (where possible ) has Two clear, legible markings in visible locations per packaging piece (when in use).

It is also Vital, to ensure that No ISPM markings are later covered, wholly or partially by the addition of labels, Stickers or document holders etc. Custom officials may not remove or check under labels and may deem packaging without visible markings as non-conforming.

Packaging that is constructed of 100% manufactured wood (such as Ply-wood or fibre board ) does not fall under these regulations and therefore does not need to have any ISPM stamps to conform\*.

\* Some V-EMB Packaging constructed from manufactured wood is stamped with ISPM markings.

# SHIPPING ADVICE - ISPM 15 Markings

**VOLVO**

ISPM markings must be fully visible on Export packaging

	XX-0000
	YY

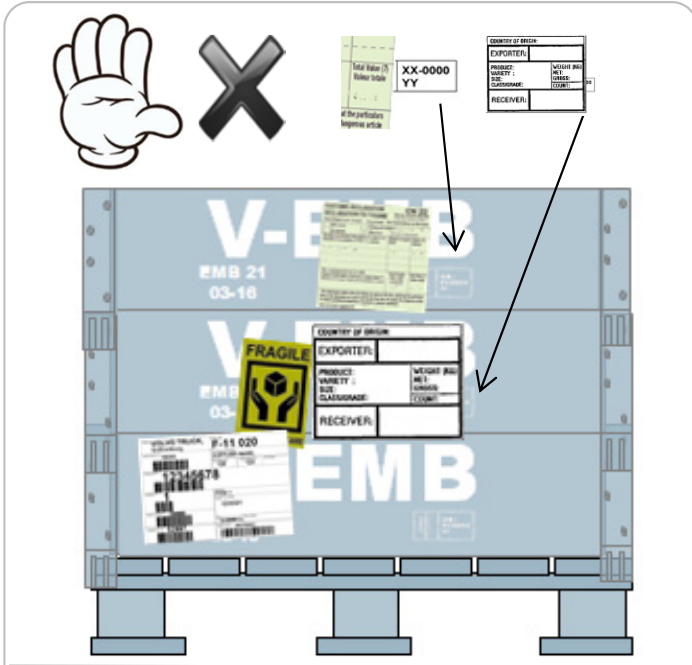

**STOP !**  
Partially / Covered ISPM Markings

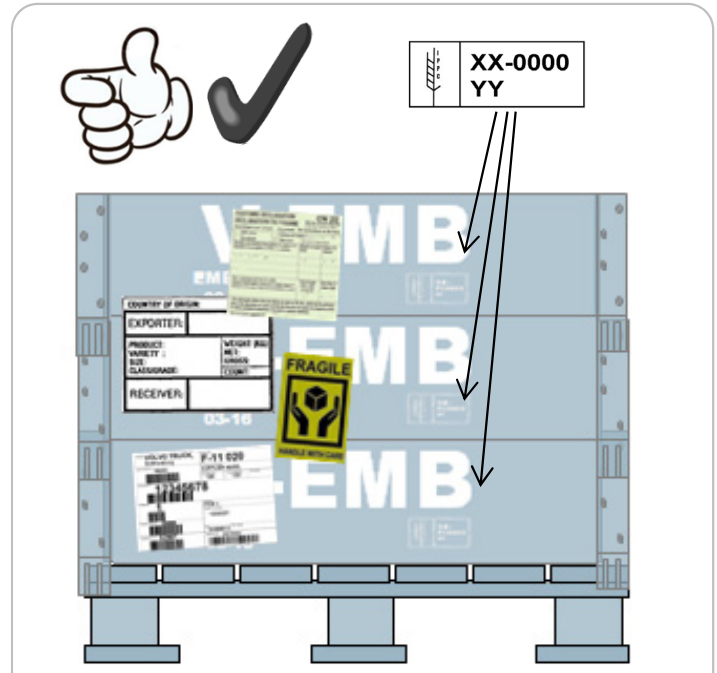

**OKAY**  
All ISPM Markings are fully visible

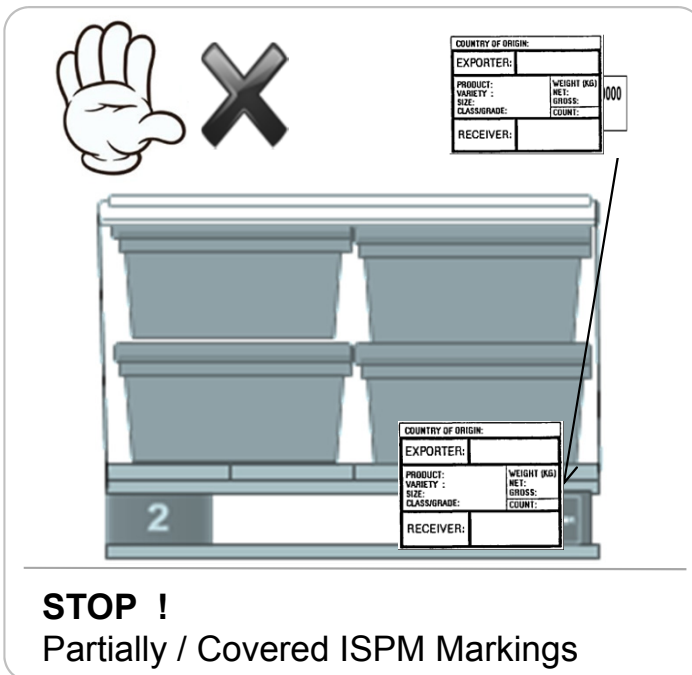

**STOP !**  
Partially / Covered ISPM Markings

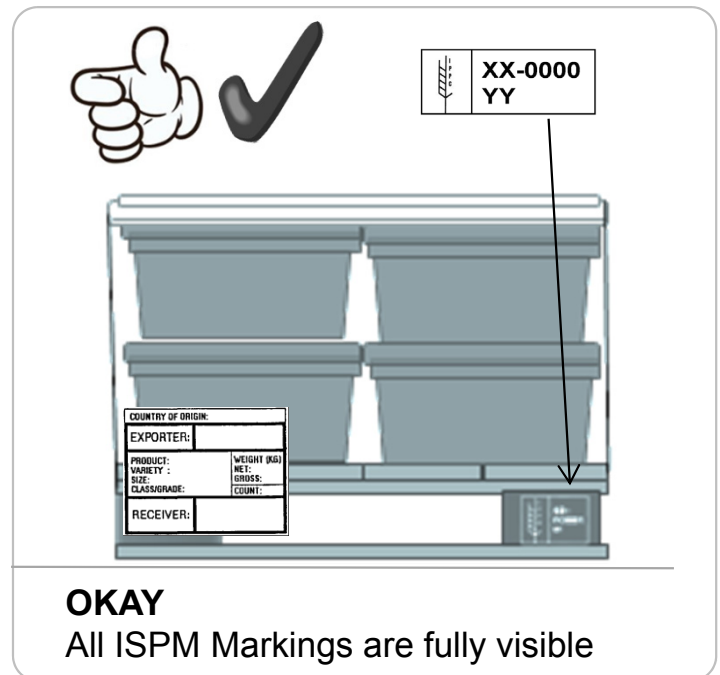

**OKAY**  
All ISPM Markings are fully visible

**No ISPM markings should be covered- wholly or partially by labels, stickers or document holders.** Custom officials may not remove or check under labels and may deem packaging without 2 visible markings per piece as non-conforming !

**Never attach labels to Plastic boxes with staples ! Staples should only be used on wood.**

## Packaging markings – What type are okay ?



### Swedish Board of Agriculture stamp

On Various wooden packaging  
Although this states heat-treatment : This marking is not compliant for international shipments – ISPM logo markings are required -



**HT DB KD**

### TREATMENT Codes without IPPC logo

Included KD ( Kiln Dried) and DB ( De-Barked) info  
Versions not used by VOLVO.  
(may include MB - Methyl Bromide )  
Not necessarily treated to IPPC standards –  
Not compliant for international shipments



### Markings with treatment codes & Unique reg no. – but without the IPPC logo

( incorporating no or a different logo )  
these are not compliant for international shipments –  
(Even if heat treated to the same standards. )  
VOLVO POOL packaging has never used this type of mark , - these should be treated as non compliant



### OLD version of the ISPM stamp ( with IPPC logo)

Included KD ( Kiln Dried) and DB ( De-Barked) info  
Versions not used by VOLVO may include MB ( Methyl Bromide) or an additional Logo ( such as a country board)



### Latest Version ( 2012 +) of ISPM 15 stamp

Still has IPPC logo , country code and unique registration number - but DB, KD and MB have been removed ( see above)  
This marking is compliant for international shipments –



## Clarity of Markings

Whilst the regulations say that at least one Stamp must be legible – To avoid possible rejection from Customs (in particular airfreight) -try to ensure that Pallets and frames have two clear visible stamps -on each piece.

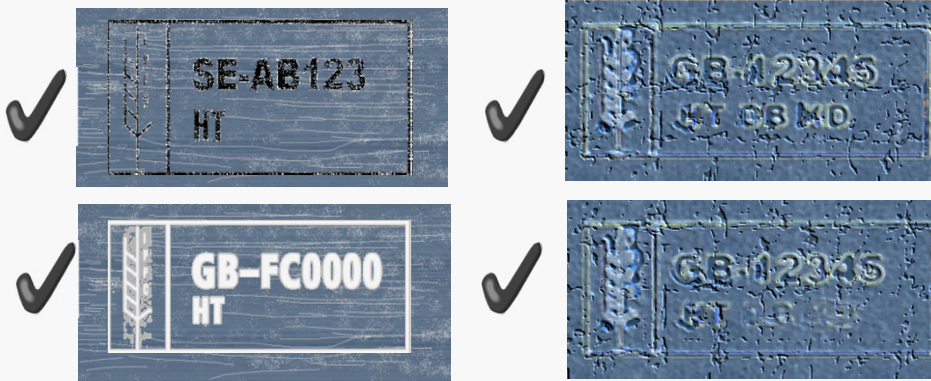

Try to avoid Markings that have unclear letters or numbers  
The IPPC 'Wheat' Logo should also be clear and visible.

## •Where to look for Markings ( Pallets)

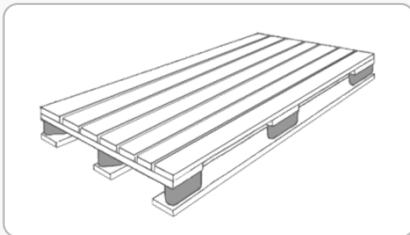

Pallets are manufactured using Solid wood and therefore need to be marked to comply .

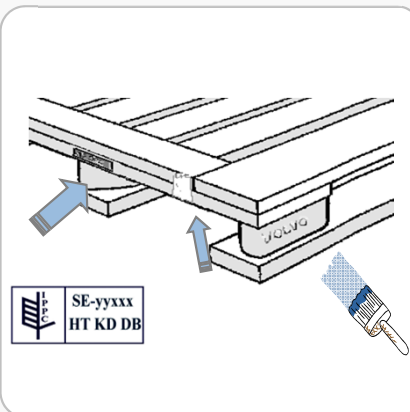

**Pallets made 1980's - 2004** – ‘Volvo’ logo on blocks  
ISPM Branded Branded burn mark on each short side ( binding board) after re- heat treatment .

\* May also have a white paint mark  
Any such pallets without the ISPM burnmarks – are not to the ISPM required standard. \*White paint marking are an aid to identification only and are not proof of compliancy !

**DUE TO THE SMALL ISPM MARK IT IS RECOMENDED THAT THE ‘VOLVO’ BRANDED PALLETTS ARE NOT USED – (Especially for Airfreight )**

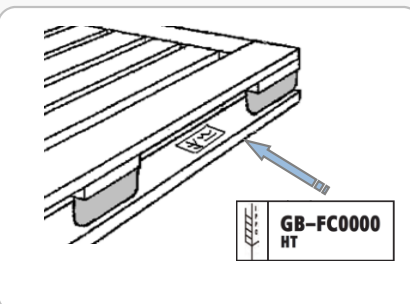

**Pallets made 2004 –2006** ‘V-EMB’ logo on blocks  
Ink Stamped mark on top right hand side of two outer runners

All V-EMB branded pallets have been treated to the new ISPM 15 standards – However pallets need to have ISPM stamps to conform

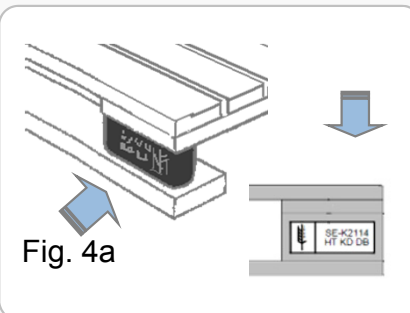

**Pallets made post 2006** ‘V-EMB’ logo on blocks  
Heat stamped ISPM Stamp into plastic blocks or Ink stamped onto Wooden blocks .

All V-EMB branded pallets have been treated to the new ISPM 15 standards – However pallets need to have the ISPM stamps to conform

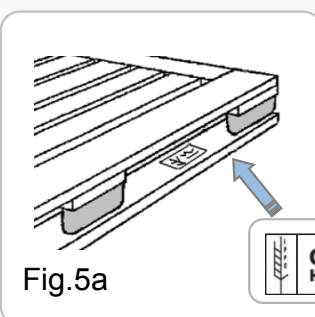

Fig.5a

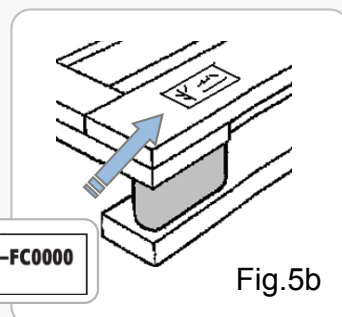
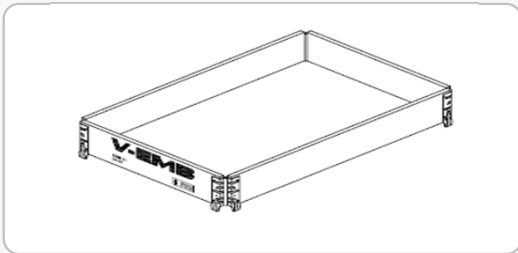

Fig.5b

**Repaired Pallets :** In Some Countries pallet repair may involve removal of previous ISPM 15 markings – these should then have New stamps on right hand side of outer runners . ISPM stamps may also be found on any newly replaced wood.

## •Where to look for Markings ( Frames )



Frames are manufactured using Solid wood and therefore need to be marked to comply .

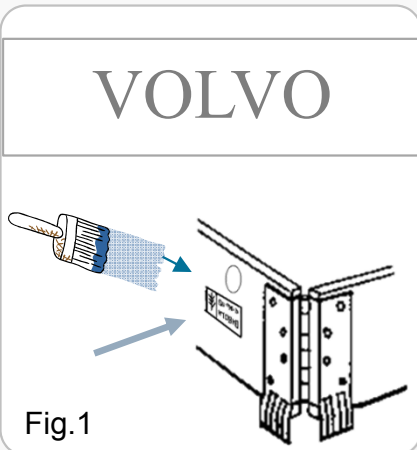

### 'VOLVO' Logo Frames made pre- 2004

Re- Heat treated & Hot branded ISPM mark – on both Short sides (right hand side) may also have white circle paint mark .

The additional paint mark is an aid to identification and **can not** be used as proof of ISPM 15 compliancy

DUE TO THE SMALL ISPM MARK IT IS RECOMENDED THAT THE 'VOLVO' BRANDED FRAMES ARE NOT USED – (Especially for Airfreight )

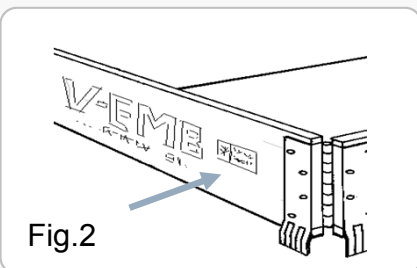

### 'V- EMB' logo Frames made post 2004-2006

INK Stamped mark on both Short sides ( Right hand side)  
All V-EMB branded Frames have been treated to the new ISPM 15 standards –

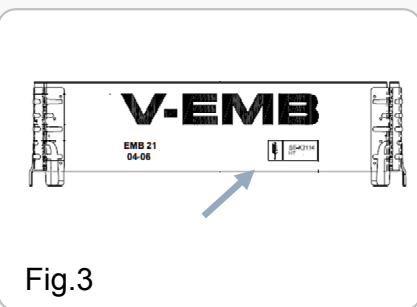

### 'V- EMB' logo Frames made post 2006

White screen print mark on both Short sides ( Right hand side)

All V-EMB branded Frames have been treated to the new ISPM 15 standards .

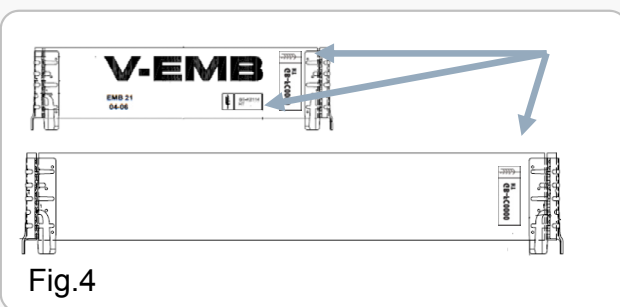

### 'V- EMB' logo Frames made post 2017

White screen print mark on both Short and long sides .

Some now have an additional stamp far right all sides

## •Where to look for Markings ( Lids)

The production process for Manufactured wood board – such as Ply and hardboard makes the need for additional heat treatment unnecessary and therefore no need for ISPM 15 stamps .  
**Spacers made 100% from ply-wood do not need to be marked**

Some of our older lids were manufactured with Solid plain -wood guiding bars.  
 If used, these need to have a ISPM logo

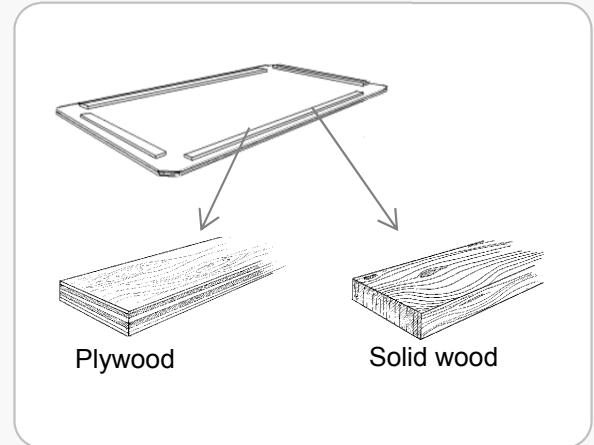

Spacers made from solid wood such as EMB 752 should have a stamp to be compliant.

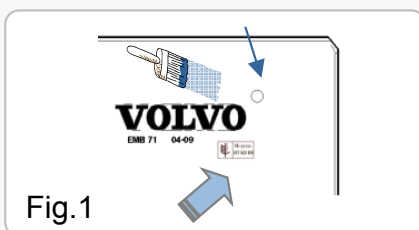

### ‘VOLVO’ Logo Lids made pre- 2004

Re- Heat treated & Hot branded ISPM mark –  
 Single mark bottom right of logo  
 ( may also have white circle paint mark . )

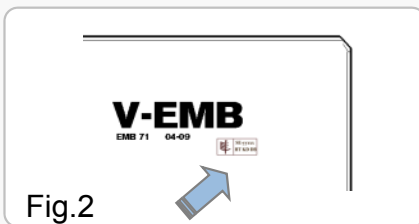

### ‘V- EMB’ logo Lids made 2004-2006

Single INK Stamp – bottom right of logo

### V- EMB logo Lids made post 2006

Single white screen printed Stamp – bottom right of logo

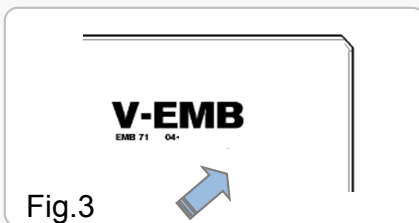

### V- EMB logo Lids made post 2010

Most Plywood lids now without ISPM Markings, as there is no requirement for Plywood to have them.



### ‘V- EMB’ logo Spacers made 2004+

Single INK Stamp – bottom right of logo





**VOLVO**

Volvo Packaging

SE-405 08 Göteborg, Sweden

[www.volvologistics.com](http://www.volvologistics.com)